

NEXTorr® UHV pumps



HIGHLIGHTS

General Features

- Extremely compact and low weight
- High and constant pumping speed for all active gases in UHV-XHV
- Pumping speed for noble gases and methane
- Long lasting in UHV-XHV
- Negligible power consumption in operation
- Reduced magnetic interference
- Able to indicate system pressure
- Maintenance-free

Applications

- Improvement of the ultimate vacuum in UHV-XHV systems
- Particle accelerators, synchrotron radiation sources
- Atom/Ion Trap systems, atomic clocks/fountains, interferometers
- Scanning/Transmission electron microscopes
- Portable vacuum instrumentation and suitcases
- Surface analysis systems
- General purpose UHV systems

The NEXTorr® UHV pumps are compact Ultra High Vacuum pumps that efficiently combine a sputter ion pump (SIP) and a Non Evaporable Getter (NEG) pump into a vacuum solution featuring high pumping speeds and capacities yet retaining a low weight and a minimal footprint.

Two versions are currently available:

- NEXTorr “D” series, based on St 172 (Zr-V-Fe) NEG alloy, operating in the UHV/XHV field since the ‘90s
- NEXTorr “Z” series, based on the novel ZAO® (Zr-V-Ti-Al) NEG alloy, developed for further improving the pumping speed and capacity for H₂, still keeping the same compact footprint

All NEXTorr D and Z series share the same sputter ion pump: CF35 and CF63 flanged models are equipped with a 6 l/s (Ar) and 15 l/s (CH₄) diode pump; CF100 flanged models are equipped with a 10 l/s (Ar), 32 l/s (CH₄) diode pump.

For applications requiring higher performances for inert gases, NEXTorr D500-StarCell and NEXTorr D1000-StarCell pumps are ideal solutions. They combine two high speed NEG cartridges (500 and 1000 l/s for H₂, respectively), with a StarCell ion pump featuring 21 l/s (Ar) and 30 l/s (CH₄), respectively.

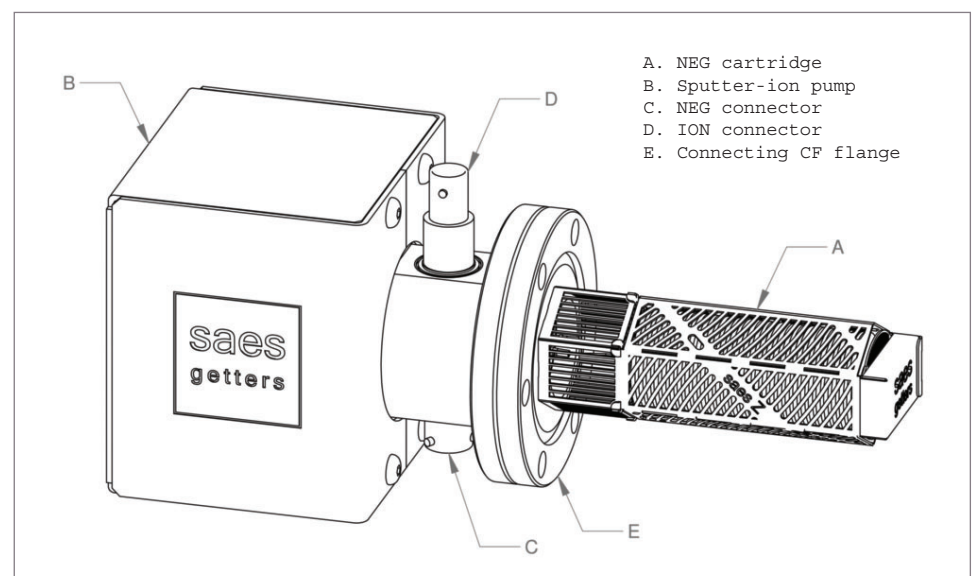

General features and performance

NEXTorr® UHV pumps

NEG SECTION				
Product Description	Alloy Type	Mass (g)	Activation Power (W)	NEG length (mm)
NEXTorr D 100-5	St 172	13.5	45	60.5
NEXTorr D 200-5	St 172	28	60	91
NEXTorr D 300-5	St 172	41	100	77
NEXTorr D 500-5	St 172	68	120	97
NEXTorr D 500-StarCell	St 172	68	120	99
NEXTorr D 1000-10	St 172	112.5	220	113
NEXTorr D 1000-StarCell	St 172	112.5	220	116
NEXTorr D 2000-10	St 172	225	280	162
NEXTorr Z 100	ZAO	30	45	64.5
NEXTorr Z 200	ZAO	58	57	91
NEXTorr Z 300	ZAO	96	110	81
NEXTorr Z 1000	ZAO	219	195	113

	Pumping Speed (l/s)				Single-run Capacity (Torr l)			
	H ₂	H ₂ O	CO	N ₂	H ₂	H ₂ O	CO	N ₂
NEXTorr D 100-5	100	90	70	40	135	10	0.7	0.4
NEXTorr D 200-5	200	180	140	80	280	18	1.3	0.6
NEXTorr D 300-5	300	270	200	100	410	45	2.2	1.3
NEXTorr D 500-5	500	450	340	200	680	70	3	1.7
NEXTorr D 500-StarCell	500	450	340	200	680	70	2.5	1.3
NEXTorr D 1000-10	1000	850	580	320	1125	440	7	4
NEXTorr D 1000-StarCell	1000	850	580	320	1125	500	6	2.5
NEXTorr D 2000-10	2000	1700	1100	640	2250	800	13	7
NEXTorr Z 100	150	100	75	40	600	9	0.6	0.35
NEXTorr Z 200	290	180	140	80	1160	16	1.5	0.7
NEXTorr Z 300	400	280	200	120	1920	40	2	1.2
NEXTorr Z 1000	1150	850	500	320	4380	400	7	4

ION SECTION						
Product Description	Type	Voltage	Flange	Pumping Speed (l/s)		Sorption Capacity (Torr l)
				CH ₄	Ar	CH ₄
NEXTorr D 100-5, D 200-5 NEXTorr Z 100, Z 200	Diode	DC +5 kV	CF35	15	6 (0.3)	50,000 hours at 10 ⁻⁶ Torr
NEXTorr D 300-5, Z 300 NEXTorr D 500-5	Diode	DC +5 kV	CF63	15	6 (0.3)	
NEXTorr D 1000-10, Z 1000 NEXTorr D 2000-10	Noble Diode	DC +5 kV	CF100	32	10 (2.5)	
NEXTorr D 500-StarCell NEXTorr D 1000-StarCell	StarCell	DC -7 kV	CF63/ CF100	30	21 (12)	80,000 hours at 10 ⁻⁶ Torr

NOTES

The models on CF63 and CF100 flanges are equipped with a thermocouple.

The activation power refers to the NEG element completely immersed in the vacuum chamber ("nude" configuration).

The "NEG length" reported in the last column is the length of the NEG element from the base flange.

The values for H₂O are estimated.

Pumping speed data refer to the initial values in nude configuration.

Single-run capacity is reached when pumping speed is equal to the pumping speed of the ion element only (this limit does not apply for H₂).

>100 reactivations (sorption cycles) are possible.

Ar pumping speed measured at 3x10⁻⁶ Torr. Unsaturated ion pump (saturated ion pump).

The NEXTorr® product line incorporates and exploits the patented concept of a combined pumping system comprising a getter pump and an ion pump, and have global Intellectual Property Rights coverage with patents already granted in the US (8,287,247), Europe (2,409,034), Japan (5,372,239), China (102356236).

The SAES Group manufacturing companies are ISO9001 certified and the Italian companies are also ISO14001 certified. Full information about our certifications for each company of the Group are available on our website at: www.saesgroup.com

D.VS.178.0.21



NEXTorr® HV pumps

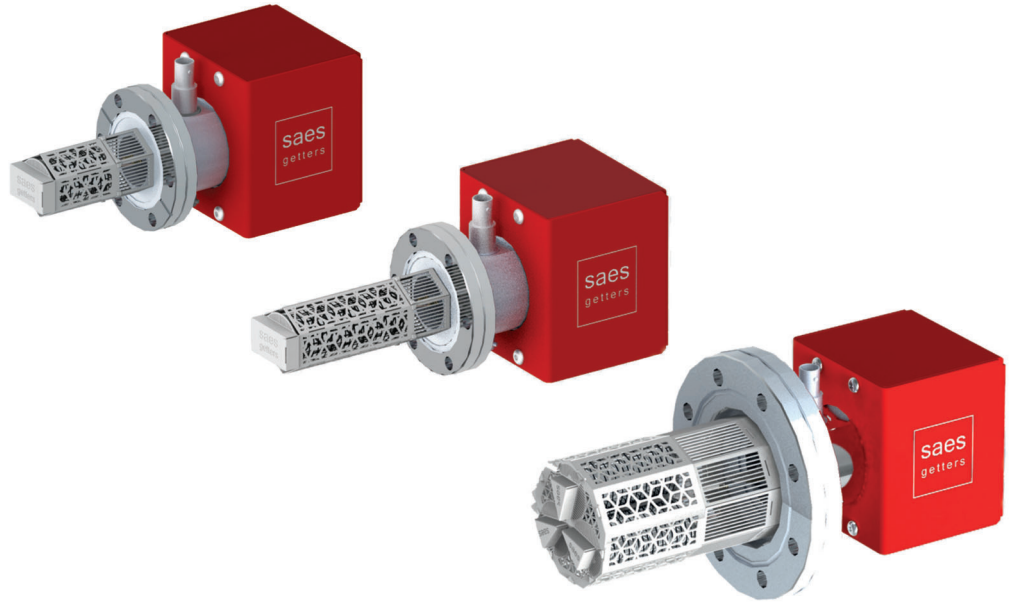

HIGHLIGHTS

General Features

- Extremely compact and low weight
- High and constant pumping speed for all active gases
- Pumping speed for noble gases and methane
- High sorption capacity in high vacuum
- Fast pump-down after air venting and without baking
- Suitable for viton-sealed and harsh systems
- Minimal power requirement during operation
- Reduced magnetic interference
- Able to indicate system pressure

Applications

- Improvement of the ultimate vacuum in HV and UHV systems
- Particle accelerators, synchrotron radiation sources
- Scanning/Transmission electron microscopes
- Portable vacuum instrumentation and suitcases
- Surface analysis systems
- Process pumps for vacuum devices and deposition chambers
- Thin films deposition systems
- Pumping, storing and releasing hydrogen isotopes

The NEXTorr® HV pumps are compact High Vacuum (HV) pumps that efficiently combine a sputter ion pump (SIP) and a Non Evaporable Getter (NEG) pump into a vacuum solution featuring high pumping speeds and large sorption capacities, yet retaining a low weight and a minimal footprint.

The NEXTorr HV pumps implement the novel ZAO® (Zr-V-Ti-Al) NEG alloy in its High Vacuum version, featuring large capacity for all the active gases.

These pumps are specifically designed and engineered to operate in the high vacuum regime (i.e. 10^{-7} – 10^{-9} Torr), and find application in all those equipment elastomer-sealed, susceptible to air permeation, and not baked out, where water sensibly contributes to the residual gas background.

In order to exploit these benefits, the NEG element of the NEXTorr HV pumps operates permanently warm at around 200 °C with a minimal power consumption.

All NEXTorr HV pumps are equipped with a noble diode ion pump, featuring pumping speed of 7 l/s (Ar) and 15 l/s (CH₄) respectively, and optimized to work in best synergy with the NEG element.

The noble diode ion pump can efficiently work in presence of non-negligible Argon throughputs typical of elastomer-sealed HV systems.

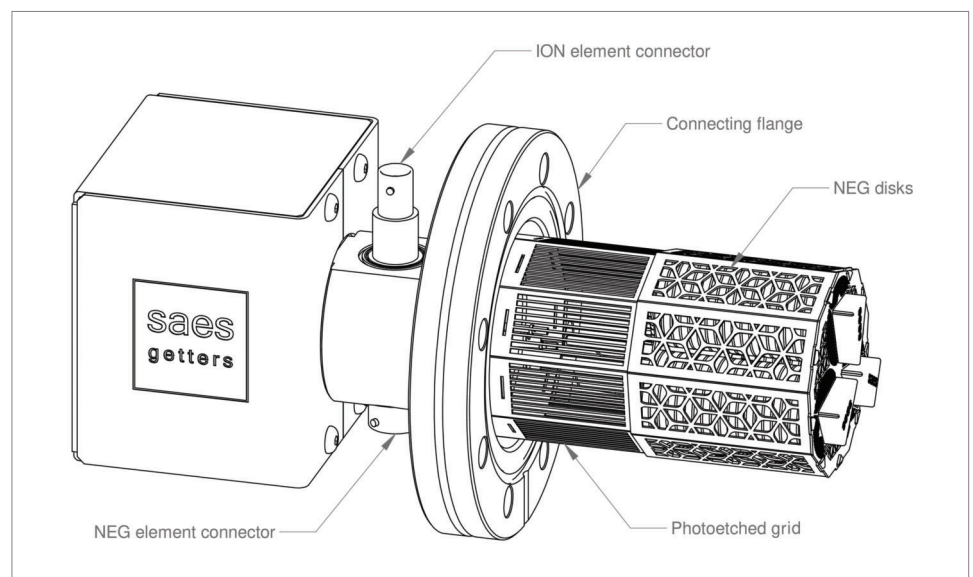

saes
group

General features and performance

NEG SECTION					
Product Description	Alloy Type	Mass (g)	Activation Power (W)	Working Power (W)	NEG length (mm)
NEXTorr HV 100	ZAO	45.5	45	5.4	64.5
NEXTorr HV 200	ZAO	84	59	7	91
NEXTorr HV 300	ZAO	200	126	12	97

NOTES

The NEXTorr HV 300 is equipped with a thermocouple.

The activation power refers to the NEG cartridge completely immersed in the vacuum chamber ("nude" configuration).

The "NEG length" reported in the last column is the length of the NEG cartridge from the base flange.

NEG SECTION										
	Pumping Speed (l/s)					Sorption Capacity (Torr l)				
	H ₂	H ₂ O	O ₂	CO ₂	N ₂	H ₂	H ₂ O	O ₂	CO ₂	N ₂
NEXTorr HV 100	80	70	55	40	25	910	86	43	10	43
NEXTorr HV 200	155	130	110	90	50	1680	150	75	18	75
NEXTorr HV 300	300	280	260	190	130	4000	380	190	45	190

NOTES

The values for H₂O are estimated.

Pumping speed data refer to the initial values, and with the NEG element completely immersed in the vacuum chamber ("nude" configuration).

The capacity values (except for H₂) are intended as the recommended absorbed quantity per run at around 200°C, allowing to perform more than 20 sorption cycles. In case of operation under lower gas loads or at RT, the pump can be reactivated 100 times or more.

The values for CO can be assumed very similar to those reported for CO₂.

ION SECTION						
NEXTorr models	Type	Voltage	Flange	Pumping Speed (l/s)		Sorption Capacity (Torr l)
				CH ₄	Ar	CH ₄
NEXTorr HV 100	Noble Diode	DC +5 kV	CF35	15	7 (0.7)	50,000 hours at 10 ⁻⁶ Torr
NEXTorr HV 200	Noble Diode	DC +5 kV	CF35	15	7 (0.7)	
NEXTorr HV 300	Noble Diode	DC +5 kV	CF63	15	7 (0.7)	

NOTE

Ar pumping speed measured at 3x10⁻⁶ Torr. Unsaturated ion pump (saturated ion pump).

NEXTorr® HV pumps

The SAES Group manufacturing companies are ISO9001 certified and the Italian companies are also ISO14001 certified. Full information about our certifications for each company of the Group are available on our website at: www.saesgroup.com

D.VS.179.0.21



The NEXTorr® product line incorporates and exploits the patented concept of a combined pumping system comprising a getter pump and an ion pump, and have global Intellectual Property Rights coverage with patents already granted in the US (8,287,247), Europe (2,409,034), Japan (5,372,239), China (102356236).

© SAES Group. Printed in Italy. All rights reserved. SAES® and NEXTorr® are registered trademarks of SAES Group. SAES Group reserves the right to change or modify product specifications at any time without notice.

SAES Group
www.saesgroup.com
neg_technology@saes-group.com